

## YL390

### 特点 PRODUCT FEATURES

- 体积小，重量轻。
- 40A触点切换能力。
- 一组常开触点形式。
- 可并联电阻或二极管供选择。

### 典型应用 TYPICAL APPLICATIONS

- 空调控制
- 卤素前大灯控制
- 喇叭控制
- 雾灯控制



### 触点负载 CONTACT DATA

型号	Model	YL390
额定负载(阻性)	Rated load	40A 14VDC / 20A 28VDC
最大切换电流	Max.Switching Current	40A
最大切换电压	Max.Switching Voltage	30VDC
最大切换功率	Max.Switching Power	560W

### 性能参数 GENERAL DATA

触点材料	Contact material	Silver Alloy		
接触电阻	Contact resistance	100mΩ Max.		
吸合时间	Operate Time	10msec. Max.		
释放时间	Release time	5msec. Max.		
绝缘电阻	Insulation resistance	100MΩ Min.(DC500V)		
介质耐压	Dielectric strength	触点与触点间	Between coil & contacts	AC 500V , 50/60Hz 1min.
		触点与线圈间	Between open contacts	AC 500V , 50/60Hz 1min.
抗振动	Humidity	稳定工作	Functional	10 ~ 55Hz , 双振幅 1.5 mm
		损坏极限	Destructive	10 ~ 55Hz , 双振幅 1.5 mm
抗冲击	Shock Resistance	稳定工作	Functional	10G Min.
		损坏极限	Destructive	100G Min.
寿命	Life	机械寿命	Electrical Life	10,000,000 次 (7,200次/小时)
		电气寿命	Mechanical Life	100,000 次(600次/小时)
环境温度	Temperature Range	-40°C ~ +105°C ( 不结冰 )		
重量	Weight	约50.0g		

YL390

线圈参数 (at 20°C) COIL DATE

Nominal Voltage 额定电压 (VDC)	Rated current 额定电流(mA) ±10%(Ω)	Coil Resistance 线圈阻值 ±10%(Ω)	Parallel resistance 并联电阻 (Ω)	Equivalent resistance 等效电阻 (Ω)	Operate Voltage 吸合电压 (Max.)	Release Voltage 释放电压 (Min.)	Max. permissible voltage 最大允许电压	Coil power 线圈功率 (W)
12	120.00	100	-	-	额定电压 的70% Rated voltage of 70%	额定电压 的10% Rated voltage of 10%	额定电压 的150% Rated voltage of 150%	1.44
24	60.00	400	-	-				1.65
12	137.61	100	680	87.2				
24	68.89	400	2700	348.6				

订货标记 ORDERING INFORMATION

YL390 -A- 12VDC -R J F -XX

产品型号 Type	YL390
触点形式 Contact Form	A-常开
线圈规格 Coil Specification	12VDC, 24VDC
配件形式 Accessory Type	无-不带电阻, R-带电阻 D1-带二极管(见接线图), D2-带二极管(见接线图)
外壳形式 Shell Form	外壳形式: 无-无胶套, J-有胶套
封装形式 Package Form	无-防尘式, F-塑封
特殊参数或特殊要求 Special Parameters Or Special Requirements	

外形尺寸、接线图 OUTLINE DIMENSIONS, WIRING DIAGRAM

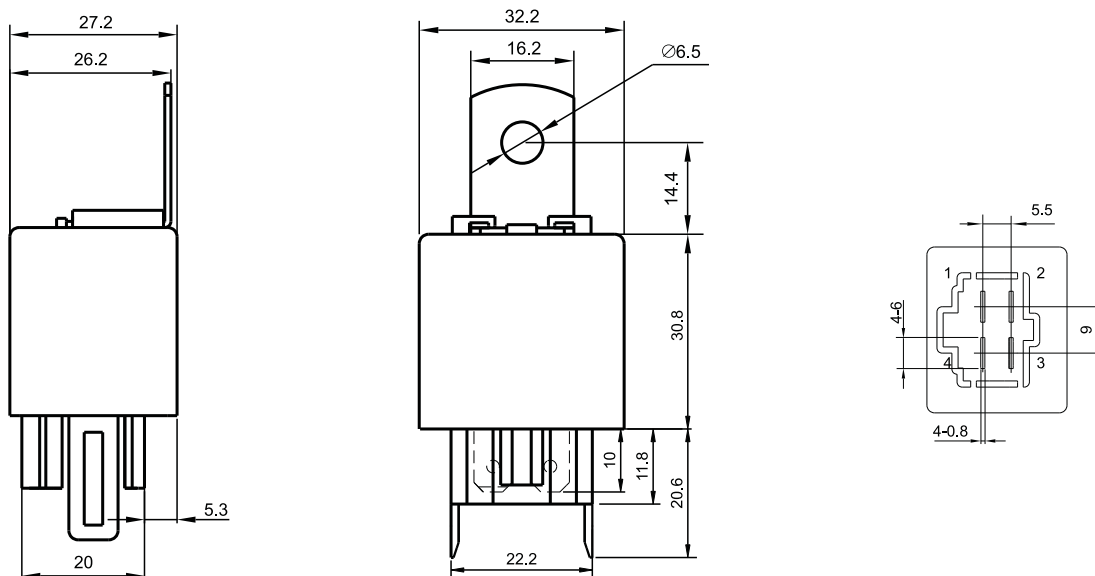

YL390

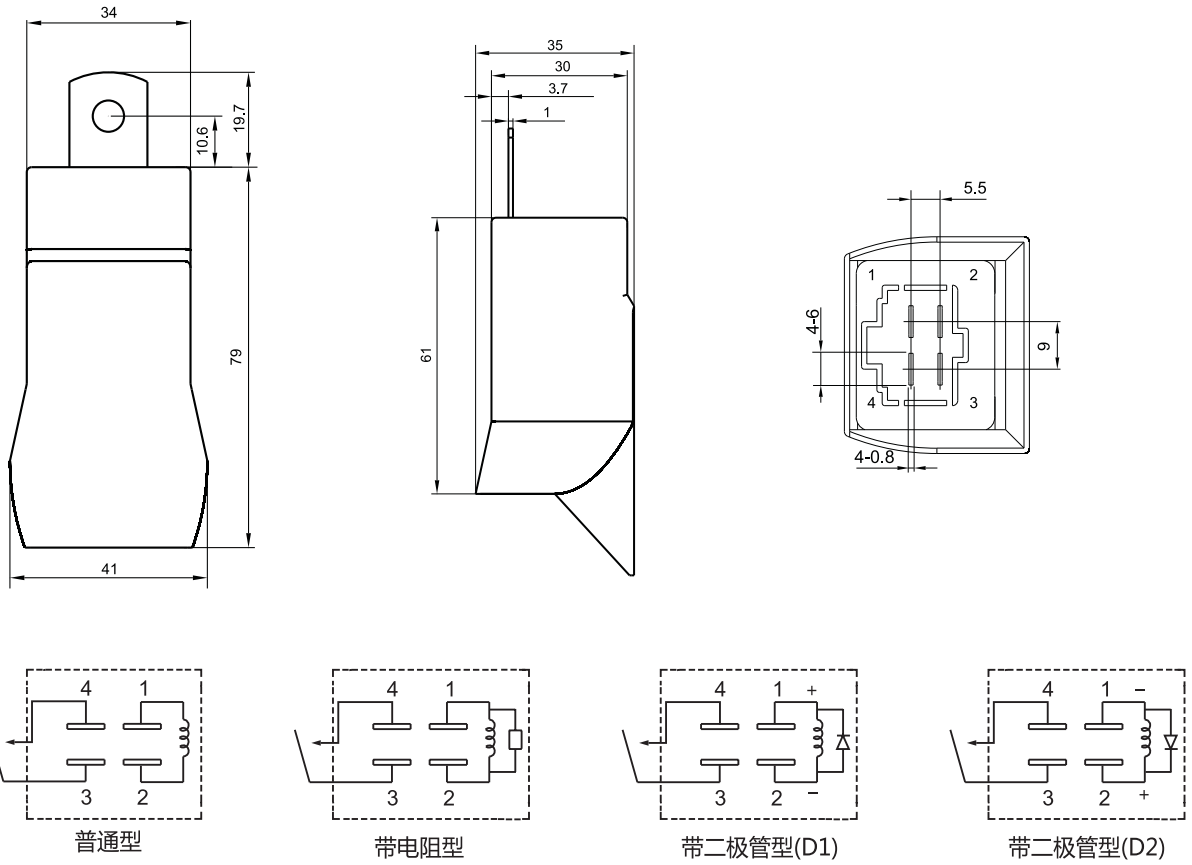

性能曲线图 REFERENCE DATA

最大直流负载断开容量  
MAX. DC LOAD DISCONNECT CAPACITY

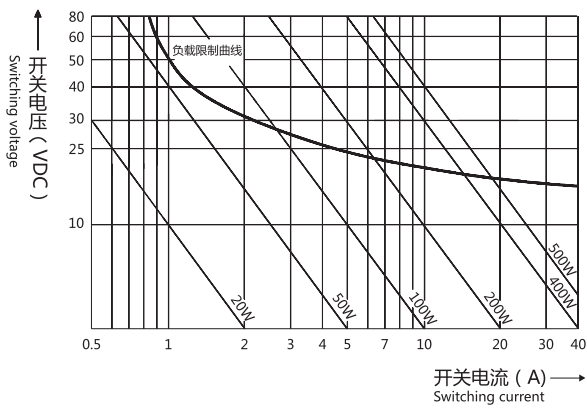

线圈工作范围  
COIL WORKING RANGE

